

# 1. ASSY DOOR

## Exploded View

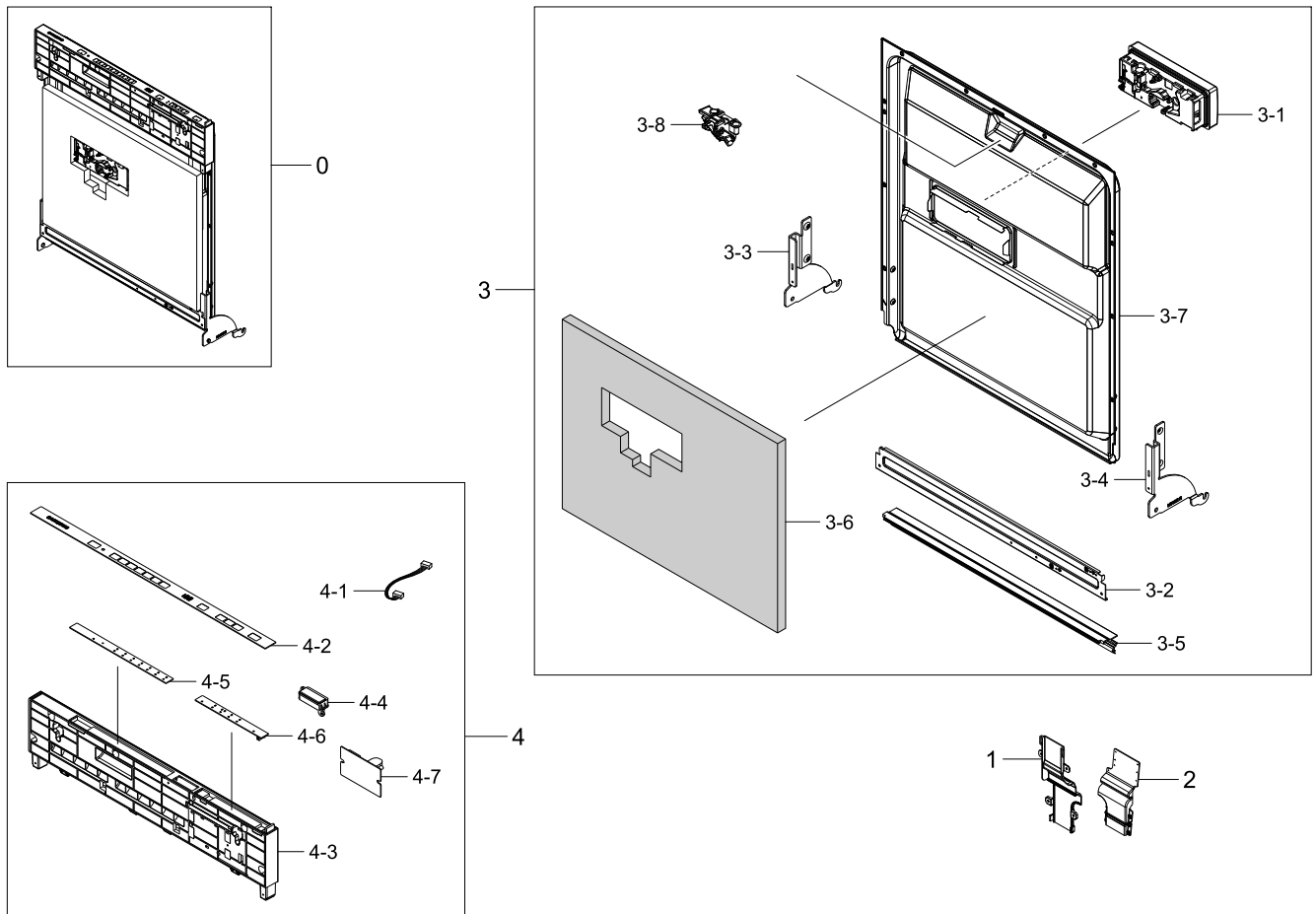

## Parts List

No.	Parent	Lvl.	Loc.	Material Code	Description & Specification	SNA	Qty.
0	DW-BG572B/XEF	1	D049	DD94-01115C	ASSY DOOR; GALA-E,DW-BG570B	SNA	1
1	DD94-01115C	2		DD63-00151A	COVER-WIRE HARNESS DOOR; GALA-E,PP	SNA	1
2	DD94-01115C	2		DD63-00152A	COVER-WIRE HARNESS BASE; GALA-E,PP	SNA	1
3	DD94-01115C	2		DD94-01089A	ASSY DOOR INNER; GALA-E	SNA	1
3-1	DD94-01089A	3		DD59-01002A	DISPENSER-SLIDE; DM-BG970T,10.0998.2X,PP	SA	1
3-2	DD94-01089A	3		DD61-00316A	BRACKET-INNER DOOR; GI-SGCC,T1.2,70,575	SNA	1
3-3	DD94-01089A	3	A079	DD61-00321A	HINGE-LEFT; SECC,T3.0,NICR COATING	SA	1
3-4	DD94-01089A	3	A078	DD61-00322A	HINGE-RIGHT; SECC,T3.0,NICR COATING	SA	1
3-5	DD94-01089A	3		DD61-00382A	HOLDER-SEAL DOOR; GALA-E,PP,PP+TPVE	SA	1

Exploded Views and Parts List

No.	Parent	Lvl.	Loc.	Material Code	Description & Specification	SNA	Qty.
3-6	DD94-01089A	3		DD63-00167A	FELT-DOOR; GALA-E,COTTON,T20,GR	SA	1
3-7	DD94-01089A	3	D5026	DD64-00080A	DOOR-INNER; FBI/SBI MODEL,STAINLESS-STS30	SNA	1
3-8	DD94-01089A	3	B041	DD66-00090A	LATCH-DOOR; DM-BG970T,PA	SA	1
4	DD94-01115C	2		DD94-01094C	ASSY PANEL CONTROL; GALA-E,DW-BG570B	SNA	1
4-1	DD94-01094C	3	M033	DD39-00006A	WIRE HARNESS-SUB; DM-BG970T,UL1569,12/6/6	SA	1
4-2	DD94-01094C	3		DD63-00173B	SHEET-INLAY WINDOW PANEL; FBI,PC SHEET	SA	1
4-3	DD94-01094C	3	C005	DD64-00090A	CONTROL-PANEL; FBI,ABS,HG0760S, BLACK	SA	1
4-4	DD94-01094C	3	C179	DD92-00012C	ASSY PCB SUB; GALA-E1_FBI,GALA FBI-SUB(BE	SA	1
4-5	DD94-01094C	3	C179	DD92-00013A	ASSY PCB SUB; GALA-FBI,GALA-TOUCH LEFT,LE	SA	1
4-6	DD94-01094C	3	C179	DD92-00014B	ASSY PCB SUB; GALA-FBI(BETTER),GALA-TOUCH	SNA	1
4-7	DD94-01094C	3	C154	DD96-00056A	ASSY DISPLAY; GALA-E1(FBI),SEGMENT,RED,52	SA	1

## 1.1. ASSY TUB

### Exploded View

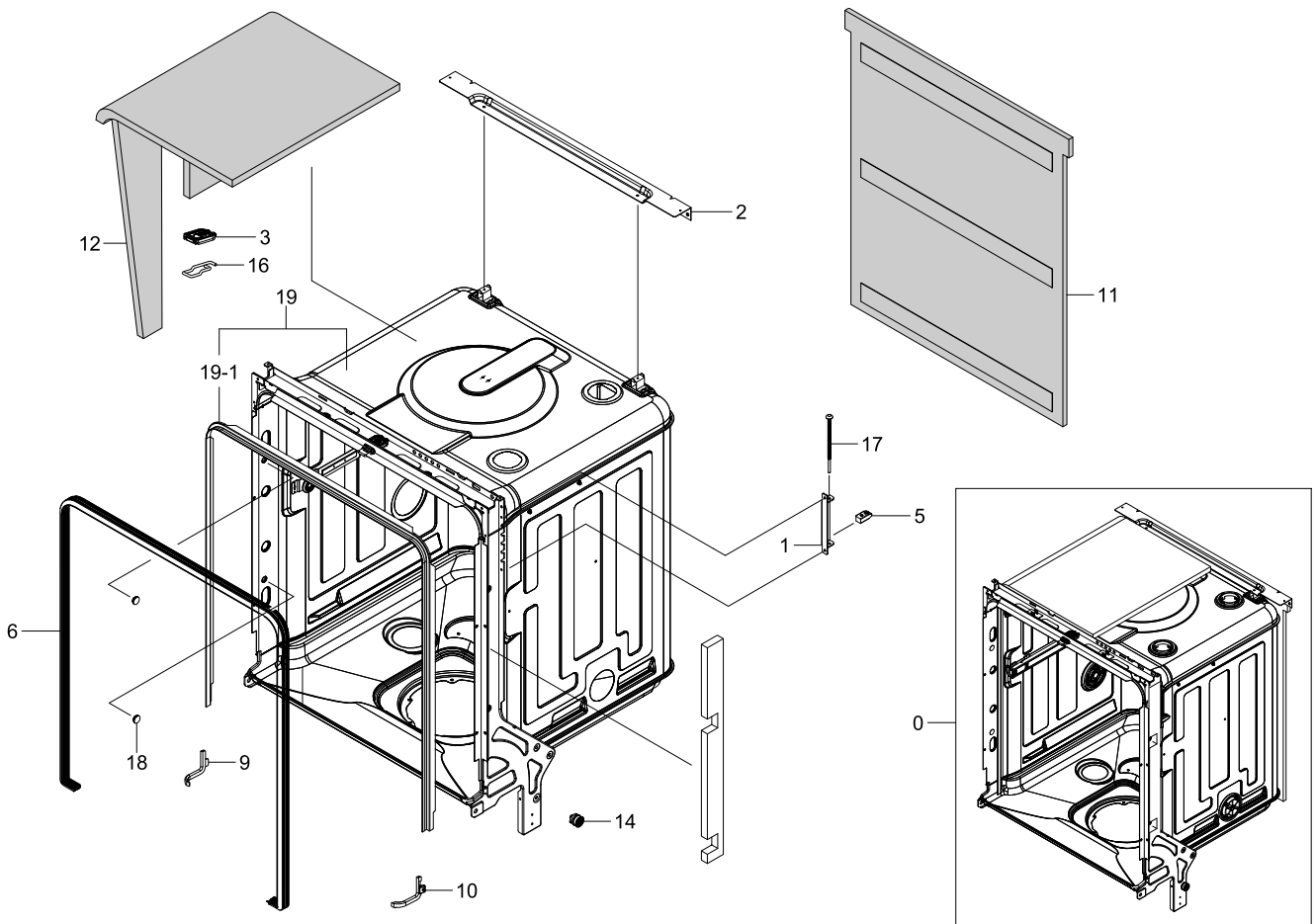

### Parts List

No.	Parent	Lvl.	Loc.	Material Code	Description & Specification	SNA	Qty.
0	DW-BG572B/XEF	1		DD94-01072D	ASSY TUB; GALA-E,DW-BG570B	SNA	1
1	DD94-01072D	2		DD61-00315A	BRACKET-DOOR ADJUSTER; GI-SGCC,T2.0,15,12	SA	2
2	DD94-01072D	2	M191	DD61-00318A	BRACKET-TOP PLATE; GI-SGCC,T1.0,220,564	SA	1
3	DD94-01072D	2		DD61-00379A	HOLDER-WIRE LATCH; GALA-E,POM,F20-03, NCG	SA	1
5	DD94-01072D	2		DD61-00388A	HOLDER-SPRING ADJUSTER; GALA-E,POM,F20-03	SA	2
6	DD94-01072D	2		DD62-00097A	SEAL-TUB PACKING; GALA-E,TPV,EP5045	SA	1
9	DD94-01072D	2		DD63-00157A	COVER-TUB EDGE L; GALA-E,PP,TB53-G644	SA	1
10	DD94-01072D	2		DD63-00158A	COVER-TUB EDGE R; GALA-E,PP,TB53-G644	SA	1

Exploded Views and Parts List

No.	Parent	Lvl.	Loc.	Material Code	Description & Specification	SNA	Qty.
11	DD94-01072D	2		DD63-00169A	FELT-TUB BACK; GALA-E,COTTON,T20,GR	SA	1
12	DD94-01072D	2		DD63-00170A	FELT-TUB TOP/LEFT; GALA-E,COTTON,T20,GR	SA	1
14	DD94-01072D	2		DD66-00020A	ROLLER-HINGE; GALA-E,POM,GRY,F20-03, NCGO	SNA	2
16	DD94-01072D	2		DD66-00079A	WIRE-LATCH; GALA-E,STS304,T3.0	SA	1
17	DD94-01072D	2		DD66-00094A	SHAFT-SPRING ADJUSTER; GALA-E,MSWR	SA	2
18	DD94-01072D	2		DD67-00074A	CAP-DOOR GUIDE; GALA-E,POM,POM, F20-03, N	SA	4
19	DD94-01072D	2		DD94-01073B	ASSY TUB SEMI; GALA-E,BETTER	SNA	1
19-1	DD94-01073B	3		DD61-00319A	BRACKET-SEAL TUB; STAINLESS-STS304,T0.5,2	SNA	1

## 1.2. ASSY CASE

### Exploded View

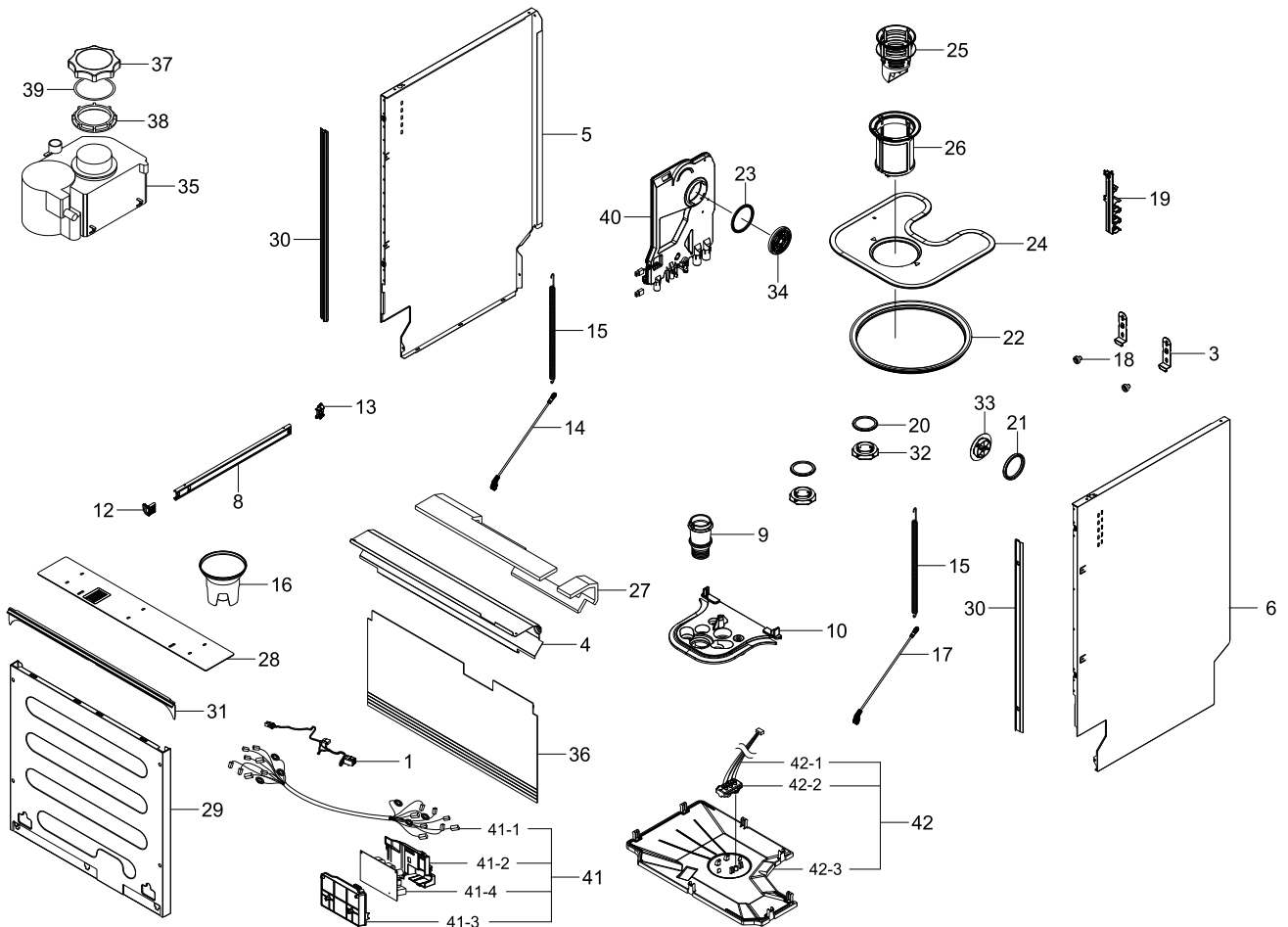

### Parts List

No.	Parent	Lvl.	Loc.	Material Code	Description & Specification	SNA	Qty.
1	DD90-00389A	2		DD39-00002A	WIRE HARNESS-OVERFLOW; DM-BG970T,UL1569 #	SA	1
3	DD90-00393A	3	P218	DD61-00176A	BRACKET-INSTALL; DMR78,GI,T0.8,R-PJT	SA	2
4	DD90-00312A	3	F149	DD61-00317A	FRAME-FRONT; GI-SGCC,T1.0,220,564,SGCC T1	SA	1
5	DD90-00389A	2		DD61-00323A	HOUSING-LEFT; BI,GI-SGCC,T0.6,W560,L860,S	SA	1
6	DD90-00389A	2		DD61-00324B	HOUSING-RIGHT; GALA-E,GI-SGCC,T0.6,BEST/B	SA	1
8	DD90-00389A	2		DD61-00329A	BRACKET-RAIL MIDDLE; STAINLESS-ST304,T0.	SA	2
9	DD90-00389A	2		DD61-00343A	SUPPORT-ROTOR LOWER; GALA-E,POM,T2.5,10g	SA	1
10	DD90-00389A	2		DD61-00393A	HOLDER-FINE FILTER BETTER; GALA-E,BETTER,	SA	1

## Exploded Views and Parts List

No.	Parent	Lvl.	Loc.	Material Code	Description & Specification	SNA	Qty.
12	DD90-00389A	2		DD61-00355A	HOLDER-RAIL MIDDLE FRONT; GALA-E,POM,GRAY	SA	2
13	DD90-00389A	2		DD61-00356A	HOLDER-RAIL MIDDLE BACK; GALA-E,POM,GRAY,	SA	2
14	DD90-00389A	2		DD61-00378A	HOLDER-ROPE DOOR (L); GALA-E,POM,POM, F20	SA	1
15	DD90-00389A	2		DD61-00389A	SPRING ETC-DOOR; GALA-E,HSWR,L350	SA	2
16	DD90-00389A	2		DD61-00390A	GUIDE-SALT; GALA-E,PP,BJ500	SA	1
17	DD90-00389A	2		DD61-00392A	HOLDER-ROPE DOOR (R); GALA-E,POM,POM F20-	SA	1
18	DD98-01005A	4		DD61-00394A	HOLDER-WOOD PANEL A; GALA-E/FBI,POM,POM	SA	2
19	DD90-00389A	2	M402	DD61-00397A	HOLDER-HOSE; GALA-E,PP,TB53-G644	SA	1
20	DD90-00389A	2		DD62-00095A	SEAL-DUCT DRY INLET; GALA-E,EPDM	SA	2
21	DD90-00389A	2		DD62-00096A	SEAL-DUCT DRY OUTLET; GALA-E,EPDM	SA	1
22	DD90-00389A	2	A026	DD62-00098A	SEAL-SUMP; GALA-E,EPDM	SA	1
23	DD90-00389A	2	F052	DD63-00072A	GASKET-BRAKE; DMR78,EPDM,BLK,R-PJT	SA	1
24	DD90-00389A	2	F472	DD63-00141A	FILTER-FINE; GALA-E,STS304 T0.4 PI 0.7,T0	SA	1
25	DD90-00389A	2	F471	DD63-00148A	FILTER-COARSE; GALA-E,PP,TB53-G644	SA	1
26	DD90-00389A	2	A029	DD63-00149A	FILTER-MICRO; GALA-E,PP,PP(TB53-G644)+MES	SA	1
27	DD90-00312A	3		DD63-00168A	FELT-FRAME FRONT; GALA-E,COTTON,T20,GR	SA	1
28	DD90-00389A	2		DD63-00172A	PROTECTOR-TOP; GALA-E,PC	SA	1
29	DD90-00389A	2	D5027	DD64-00087A	DOOR-OUTER; FBI/SBI,EGI-SECC,T0.6,SECC T0	SA	1
30	DD90-00389A	2	Z780	DD64-00095A	TRIM-SIDE; GALA-E,PP+TPV,BLK	SA	2
31	DD90-00389A	2	U010	DD64-00097A	TRIM-UPPER; GALA-E,PP,BLK,PP+TPV	SA	1
32	DD90-00389A	2		DD67-00070A	CAP-INLET DRY; GALA-E,PP,TB53-G644	SA	2
33	DD90-00389A	2		DD67-00071A	CAP-OUTLET DRY; GALA-E,PP,TB53-G644	SA	1
34	DD90-00389A	2		DD67-00073A	CAP-CASE BRAKE; GALA-E,PP,PP+T30, TB53-G6	SA	1
35	DD90-00389A	2		DD67-00083A	TANK WATER-SOFTNER; DM-BG970T,PP,Solenoid	SA	1
36	DD90-00389A	2		DD67-00084A	RUBBER-SKIRT; GALA-E,NR	SA	1

No.	Parent	Lvl.	Loc.	Material Code	Description & Specification	SNA	Qty.
37	DD90-00389A	2		DD67-00086A	TANK WATER-SOFTNER-CAP; DM-BG970T,PP	SA	1
38	DD90-00389A	2		DD67-00087A	TANK WATER-SOFTNER-HOLDER; DM-BG970T,PP	SA	1
39	DD90-00389A	2		DD67-00088A	TANK WATER-SOFTNER SEAL; DM-BG970T,NBR,3.	SA	1
40	DD90-00389A	2		DD94-01091A	ASSY CASE BRAKE; GALA-E	SA	1
41	DD90-00389A	2		DD92-00028A	ASSY COVER PCB(M); GALA-PJT,DW-SG520W/XEO	SNA	1
41-1	DD92-00028A	3		DD39-00005B	WIRE HARNESS-MAIN; DW-SG520T,UL1569, UL10	SA	1
41-2	DD92-00028A	3		DD63-00175A	COVER-PCB UPPER; GALA-E,PP	SNA	1
41-3	DD92-00028A	3		DD63-00176A	COVER-PCB LOWER; GALA-E,PP	SNA	1
41-4	DD92-00028A	3	F316	DD92-00011C	ASSY PCB MAIN; GALA-E1,GALA-MAIN(FBI_BETT	SA	1
42	DD90-00389A	2	F405	DD94-01113A	ASSY COVER BASE; GALA-E	SA	1
42-1	DD94-01113A	3		DD39-00001A	WIRE HARNESS-LEAKAGE; DM-BG970T,UL1569 #2	SA	1
42-2	DD94-01113A	3		DD61-00375A	HOLDER-SENSOR LEAKAGE; GALA-E,PP,BJ500	SNA	1
42-3	DD94-01113A	3		DD63-00155A	COVER-BASE; GALA-E,PP,PP, BJ500	SNA	1

### 1.3. ASSY ROTOR&DUCT DRY

#### Exploded View

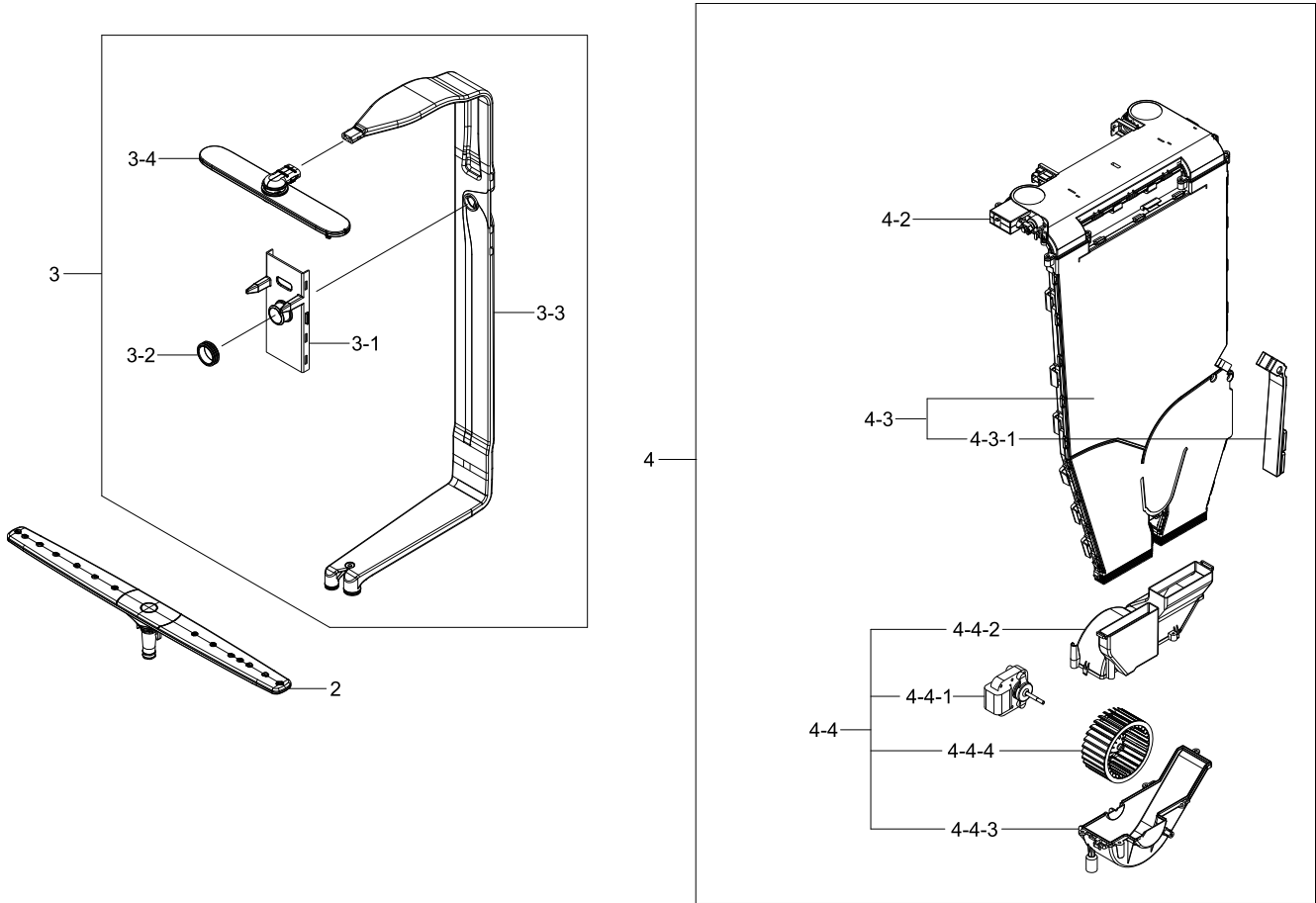

#### Parts List

No.	Parent	Lvl.	Loc.	Material Code	Description & Specification	SNA	Qty.
2	DD90-00389A	2	F442	DD94-01083A	ASSY ROTOR LOWER; GALA-E	SA	1
3	DD90-00389A	2		DD94-01114A	ASSY DUCT; GALA-E	SA	1
3-1	DD94-01114A	3		DD61-00334A	HOLDER-DUCT MIDDLE; GALA-E,POM,F20-03, NC	SNA	1
3-2	DD94-01114A	3		DD62-00101A	SEAL-HOLDER DUCT MIDDLE; GALA-E,EPDM,EPDM	SNA	1
3-3	DD94-01114A	3	P050	DD67-00078A	DUCT-MAIN; GALA-E,PP,M910	SA	1
3-4	DD94-01114A	3	F444	DD94-01082A	ASSY ROTOR UPPER; GALA-E	SA	1
4	DD90-00389A	2		DD94-01117C	ASSY DUCT DRY; GALA-E,BEST/BETTER	SA	1
4-2	DD94-01117C	3		DD94-01100B	ASSY DUCT-DRY UPPER; GALA-E,BETTER	SNA	1
4-3	DD94-01117C	3		DD94-01101B	ASSY DUCT-DRY MIDDLE; GALA-E,BEST/BETTER	SNA	1
4-3-1	DD94-01101B	4		DD63-00179A	COVER-DUCT MIDDLE HOLE; GALA-E,EPDM	SNA	1



No.	Parent	Lvl.	Loc.	Material Code	Description & Specification	SNA	Qty.
4-4	DD94-01117C	3	M020	DD96-00055B	ASSY MOTOR FAN; GALA-E,BETTER/BEST	SNA	1
4-4-1	DD96-00055B	4		3103-001268	FAN-AC; 230V,117mA,2150rpm,470g	SA	1
4-4-2	DD96-00055B	4		DD63-00145A	COVER-BLOWER UPPER; GALA-E,PP,TB53-G644	SNA	1
4-4-3	DD96-00055B	4		DD63-00146A	COVER-BLOWER LOWER; PP,TB53-G644	SNA	1
4-4-4	DD96-00055B	4		DD67-00077A	BLOWER; GALA-E,PP	SNA	1

# 1.4. ASSY BASKET PARTS

## Exploded View

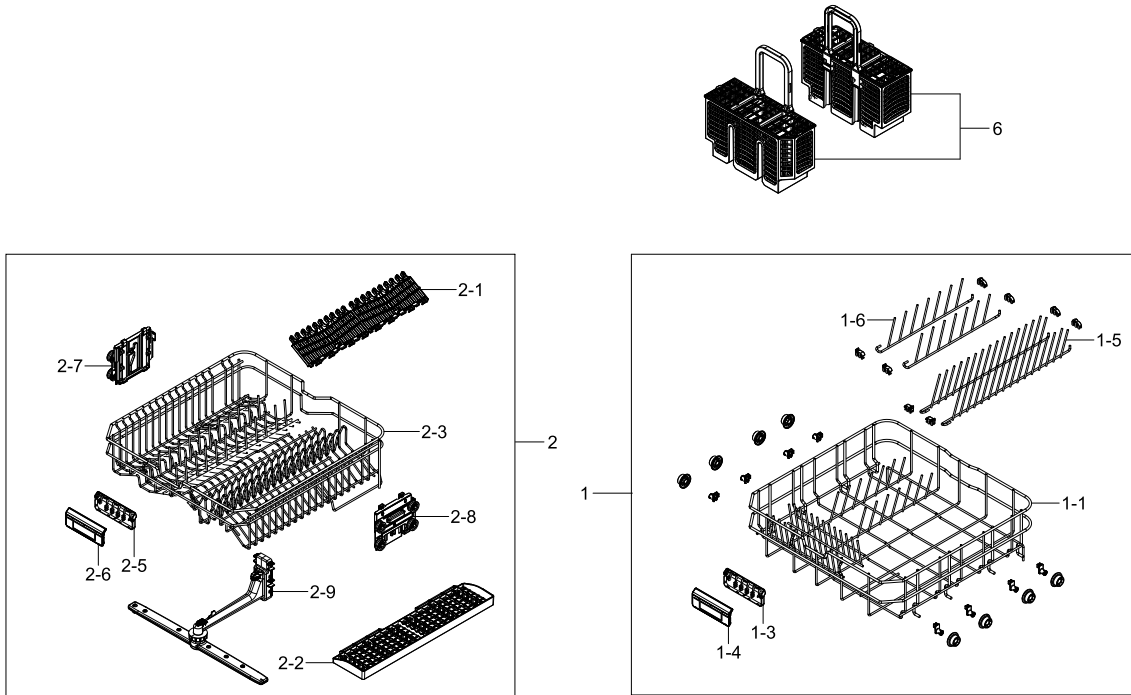

## Parts List

No.	Parent	Lvl.	Loc.	Material Code	Description & Specification	SNA	Qty.
1	DD90-00389A	2		DD94-01088A	ASSY BASKET LOWER; GALA-E	SA	1
1-1	DD94-01088A	3	A041	DD61-00385A	BASKET-LOWER; GALA-E,MSWR6,NYON11	SA	1
1-3	DD94-01103D	3		DD64-00082A	HANDLE-BASKET LOWER; GALA-E,PP,PP+30, TB5	SA	1
1-4	DD94-01103D	3		DD64-00104A	HANDLE-BASKET UPPER (STS); GALA-E,PP,TB53	SNA	1
1-5	DD94-01088A	3		DD66-00083A	WIRE-FOLDING SOUP R; GALA-E,MSWR6,NYON11	SA	2
1-6	DD94-01088A	3		DD66-00086A	WIRE-FOLDING DINNER FL; GALA-E,MSWR6,NYON	SA	2
2	DD90-00389A	2		DD94-01103D	ASSY BASKET MIDDLE; GALA-E	SA	1
2-1	DD94-01103D	3	F127	DD61-00344A	SUPPORT-CUP; GALA-E,PP,PP+T30, TB53-G644	SNA	2

No.	Parent	Lvl.	Loc.	Material Code	Description & Specification	SNA	Qty.
2-2	DD94-01103D	3		DD61-00345A	SUPPORT-KNIFE; GALA-E,PP,T2.5,GRAY,TB53-G	SA	1
2-3	DD94-01103D	3		DD61-00384A	BASKET-MIDDLE; GALA-E,MSWR6,NYON11	SA	1
2-5	DD94-01103D	3		DD64-00082A	HANDLE-BASKET LOWER; GALA-E,PP,PP+30, TB5	SA	1
2-6	DD94-01103D	3		DD64-00104A	HANDLE-BASKET UPPER (STS); GALA-E,PP,TB53	SNA	1
2-7	DD94-01103D	3		DD94-01105A	ASSY BASKET ADJUSTER L; GALA-E	SA	1
2-8	DD94-01103D	3		DD94-01106A	ASSY BASKET ADJUSTER R; GALA-E	SA	1
2-9	DD94-01103D	3		DD94-01116A	ASSY ROTOR MID; GALA-E	SA	1
6	DD90-00389A	2		DD94-01110A	ASSY BASKET-CUTLERY; GALA-E,PP/GRAY	SA	2

## 1.5. ASSY BASE

### Exploded View

#### Parts List

No.	Parent	Lvl.	Loc.	Material Code	Description & Specification	SNA	Qty.
0	DW-BG572B/XEF	1		DD94-01090B	ASSY BASE; GALA-E,DW-BG570B / DW-SG520T	SNA	1
1	DD94-01090B	2		DD29-00007A	FILTER EMI; DFCA-2515VF-22C14GW,DW-FG720W	SA	1
2	DD94-01090B	2	F336	DD61-00281A	CASE-GEAR; DMT800,PP+TALC,GRY,R3-PJT	SA	1
3	DD94-01090B	2		DD61-00330A	FOOT-BUILT IN; GALA-E,PP,TB53-G644	SA	3
4	DD94-01090B	2		DD61-00333A	HOLDER-HOSE 1WAY; POM,POM, F20-03, NCGO55	SA	1
5	DD94-01090B	2	F355	DD61-00360A	PLATE-BASE; GALA-E,PP,PP, BJ500	SA	1
6	DD94-01090B	2		DD61-00376A	HOLDER-HOSE INLET; GALA-E,POM,POM, F20-03	SA	1
7	DD94-01090B	2		DD61-00377A	HOLDER-HOSE OUTLET; GALA-E,POM,F20-03, NC	SA	1
8	DD94-01090B	2		DD62-00102A	VALVE-SAFETY; DM-BG970T,PA66,1570mm,0.2-1	SA	1
9	DD94-01090B	2	F167	DD65-00001G	CLAMPER HOSE; GALA-E,SK5,ID23.7	SA	1
10	DD94-01090B	2	F165	DD65-00001J	CLAMPER HOSE; GALA-E,SK5,ID14.8	SA	1
11	DD94-01090B	2	F346	DD66-00052A	GEAR-WORM; DMT800,PA,NTR,1300CRH	SA	1
12	DD94-01090B	2	F345	DD66-00053A	GEAR-HELICAL; GALA-E,PA6,NTR	SA	1
13	DD94-01090B	2		DD66-00097A	SHAFT-ADJUST FOOT; GALA-E,SWRCH 10A,SWRCH	SA	1
14	DD94-01090B	2	A032	DD67-00079A	HOSE-DRAIN; GALA-E,PP	SA	1
15	DD94-01090B	2	M015	DD81-01307A	POWER CORD; 1700mm	SA	1

## 1.6. ASSY SUMP

### Exploded View

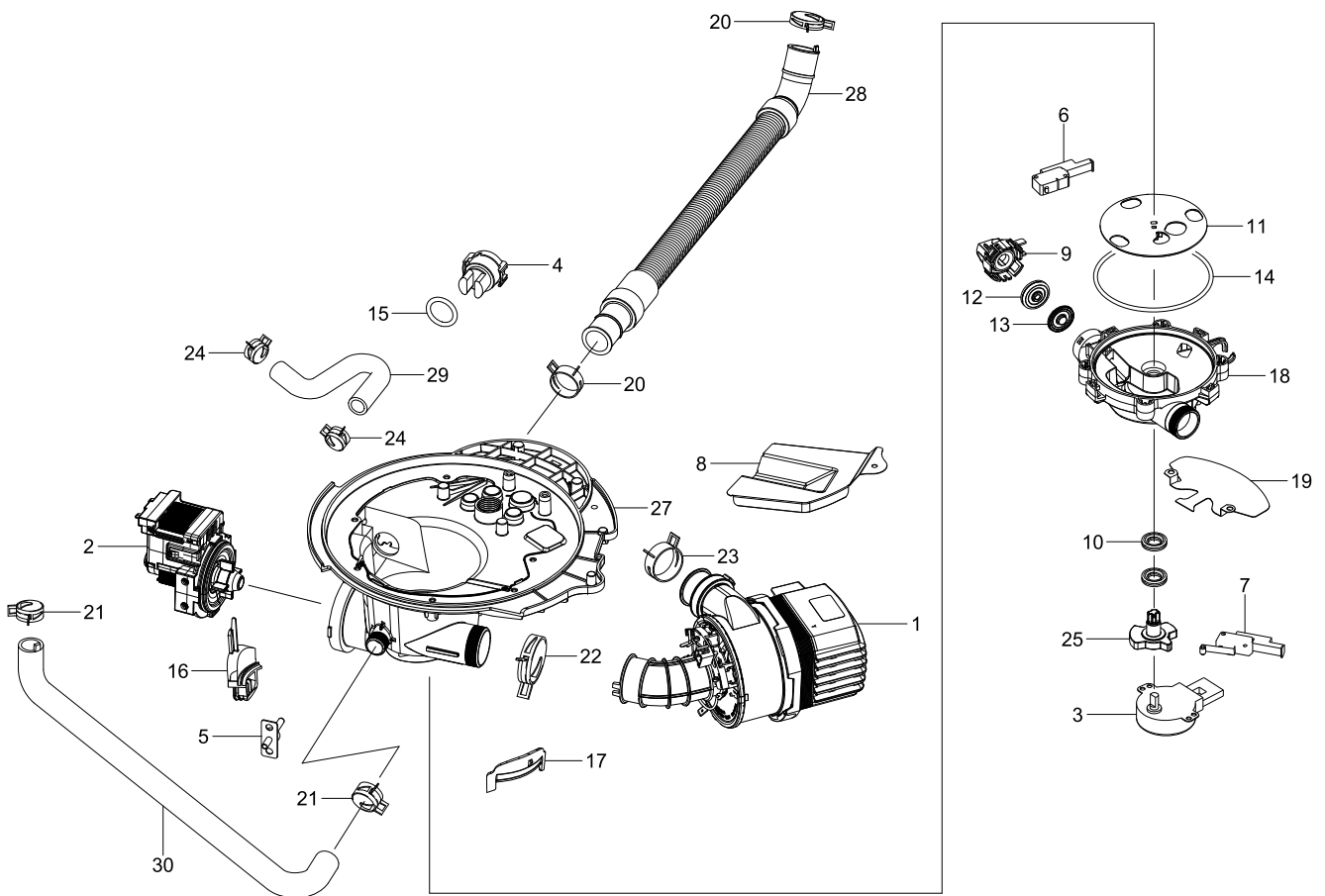

### Parts List

No.	Parent	Lvl.	Loc.	Material Code	Description & Specification	SNA	Qty.
1	DD94-01078C	2		DD31-00014A	PUMP-AC; CS-0204SA,230V,50Hz	SA	1
2	DD94-01078C	2	A007	DD31-00012A	PUMP-DRAIN; 230V,50Hz	SA	1
3	DD94-01078C	2		DD31-00013A	MOTOR GEARED; SSM-23H,2.5,8,230V,40m,DM-B	SA	1
4	DD94-01078C	2	F089	DD32-00008A	SENSOR-TURBIDITY; GSGTST06,Turbidity sens	SA	1
5	DD94-01078C	2	M117	DD32-00009A	THERMISTOR; 17.59k,12,-25 to +105,5,5	SA	1
6	DD94-01078C	2		DD34-00005A	SWITCH MICRO; SZM-V01-FA-33,PT-Au-Ag-Ni-C	SA	1
7	DD94-01078C	2		DD34-00006A	SWITCH MICRO; SZM-V01-6FA-33,PT-Au-Ag-Ni-	SA	1
8	DD94-01078C	2		DD61-00364A	BRACKET-MOTOR MOUNTING; GALA-E,SGCC,T0.4	SA	1
9	DD94-01078C	2		DD61-00383A	HOLDER-HPS SWITCH; GALA-E,POM,GRAY,F20-03	SA	1

No.	Parent	Lvl.	Loc.	Material Code	Description & Specification	SNA	Qty.
10	DD94-01078C	2	F207	DD62-00054A	SEAL-DISTRIBUTER; GALA-E,SILICON,BLK	SA	2
11	DD94-01078C	2	F064	DD62-00091A	VALVE-DISTRIBUTER; GALA-E,POM,F20-03, NCG	SA	1
12	DD94-01078C	2		DD62-00092A	SEAL-HPS SWITCH A; GALA-E,SILICON	SA	1
13	DD94-01078C	2		DD62-00093A	SEAL-HPS SWITCH B; GALA-E,SILICON	SA	1
14	DD94-01078C	2		DD62-00105A	SEAL-COVER DISTRIBUTE; GALA-E,NBR	SA	1
15	DD94-01078C	2		DD62-00106A	SEAL-SOIL SENSOR; GALA-E,EPDM	SA	1
16	DD94-01078C	2		DD63-00142A	COVER-DRAIN PUMP; GALA-E,PP+T20,TH72-G644	SA	1
17	DD94-01078C	2		DD63-00143A	COVER-CIRCULATION PUMP; GALA-E,PP+T20,TH7	SA	1
18	DD94-01078C	2		DD63-00144A	COVER-DISTRIBUTE; GALA-E,PP+T20,TH72-G644	SA	1
19	DD94-01078C	2		DD63-00184A	PROTECTOR-SYN MOTOR; GALA-E,PET	SA	1
20	DD94-01090B	2	F167	DD65-00001G	CLAMPER HOSE; GALA-E,SK5,ID23.7	SA	1
21	DD94-01078C	2	F166	DD65-00001H	CLAMPER HOSE; GALA-E,SK5,ID19	SA	2
22	DD94-01078C	2	F152	DD65-00001L	CLAMPER HOSE; GALA-E,SK5,DACRO COAT	SA	1
23	DD94-01078C	2	F152	DD65-00001M	CLAMPER HOSE; GALA-E,SK5,DACRO COAT	SA	1
24	DD94-01078C	2	F152	DD65-00001N	CLAMPER HOSE; GALA-E,SK5,DACRO COAT	SA	2
25	DD94-01078C	2		DD66-00060A	CAM-DISTRIBUTE; GALA-E,POM,F20-03, NCGO55	SA	1
27	DD94-01078C	2		DD67-00065A	SUMP; GALA-E,PP+T20,TH72-G644	SA	1
28	DD94-01078C	2	F352	DD67-00080A	HOSE-DRAIN IN; GALA-E,PP+TPV,PP+TPE+EPDM+	SA	1
29	DD94-01078C	2		DD67-00081A	HOSE-SOFTNER IN; GALA-E,EPDM	SA	1
30	DD94-01078C	2		DD67-00082A	HOSE-WATER LEVEL SENSOR; GALA-E,EPDM	SA	1